

Copyright Notice

This documentation and the software included with this product are copyrighted 1994 by Advantech Co., Ltd. All rights are reserved. Advantech Co., Ltd. reserves the right to make improvements to the products described in this manual at any time without notice.

No part of this manual or software may be reproduced, copied, translated or transmitted, in any form or by any means without the prior written permission of Advantech Co., Ltd. Information provided in this manual is intended to be accurate and reliable. However, Advantech Co., Ltd. assumes no responsibility for its use, nor for any infringements of rights of third parties which may result from its use.

Acknowledgments

PC-LabCard is a trademark of Advantech Co., Ltd. IBM, PC and PC/XT/AT are trademarks of International Business Machines Corporation. MS-DOS, MASM, QuickBASIC, Microsoft C and MS-PASCAL are trademarks of Microsoft Corporation. Intel is a trademark of Intel Corporation. Turbo C and Turbo PASCAL are trademarks of Borland International. MOXA is a trademark of 404 Technologies Inc.

Contents

CHAPTER 1	Introduction	1
	Description	2
CHAPTER 2	Hardware Configuration	7
	Initial inspection	8
	Switch and jumper layout	9
	Jumper settings	10
	Card configuration	10
	Protocol selection	11
	I/O address and interrupt setup	13
CHAPTER 3	Installation	21
	Card installation	22
CHAPTER 4	Software Installation	23
	Driver Installation for DOS Users	24
	DOS driver installation	29
	Programming	30
	Driver installation for Windows users	31
CHAPTER 5	Software Installation for UNIX Users	33
	SCO UNIX/XENIX	34
CHAPTER 6	Wiring	37
	RS-232 wiring	38
	RS-422 wiring	40
	RS-485 wiring	41
APPENDIX A	Connector Pin Assignments	43
	RS-232 pin assignments	44
	RS-422 pin assignments	45
	RS-485 pin assignments	46
APPENDIX B	PC I/O Address Reference	47
	PC I/O address table	48

CHAPTER

1

Introduction

Description

The PCL-746+ is a four port serial communication interface card. Each port can be configured individually to either RS-232, RS-422 or RS-485 using on-board jumpers.

The PCL-746+'s four 16C550 UARTs (on-chip 16-byte FIFO buffers) make serial I/O more reliable. By buffering data into 16-byte packets before putting it on the bus the UARTs drastically reduce the CPU load. This makes the PCL-746+ especially suitable for high speed serial I/O applications under MS Windows.

The PCL-746+ supports two operation modes: standard mode and enhanced mode. In standard mode each of the four ports can be set up individually as either the address or the IRQ channel. In enhanced mode, all four ports can be set to share the same IRQ. When an on-board interrupt occurs the interrupt status register indicates which port has generated it. The shared interrupt can be set to most common (extended) AT interrupts. This simplifies programming, speeds up interrupt processing and frees up interrupts for other devices.

In RS-485 mode, the PCL-746+ automatically senses the direction of incoming data and switches its transmission direction accordingly. Therefore no handshaking signal (e.g. RTS signal) is necessary. This feature lets you simply and quickly build an RS-485 network with just two wires. More importantly, application software previously written for half duplex RS-232 environments, can be maintained without need for modification.

Each card comes with DOS drivers and PC-ComLIB, a serial communication library. PC-ComLIB supports most common languages, including C, Pascal, Visual Basic, assembly and Clipper. The PC-ComLIB package also includes the DataScope data viewer, terminal emulator and self-diagnostics utilities for easy troubleshooting and debugging.

Features

- Four independent RS-232, RS-422 or RS-485 serial ports
- Each port is individually configurable to RS-232, RS-422 or RS-485 (Jumper selectable)
- 16C550 UARTs for PCL-746+
- Speed up to 115 Kbps
- Complete RS-232 modem-control signals
- Up to two cards for a total of eight ports in one system
- Interrupts jumper selectable, IRQ 3, 4, 5, 7, 9, 10, 11, 12 or 15
- On-board interrupt status register for greater throughput
- Compatible with standard PC ports: COM1, COM2, COM3 or COM4
- RS-422 or RS-485 modes jumper selectable
- Automatic data flow control in RS-485 mode
- Supports 2-wire or 4-wire RS-422/RS-485 operation
- Space reserved for terminator resistor
- Space reserved for optional surge protection on all port lines (RS-422/RS-485 mode only)
- LED indicators on each port indicate data flow
- PC-ComLIB Driver included
- Compatible with Arnet 4-port cards supporting SCO UNIX/XENIX

Applications

- Interface to PLC, barcode reader, scale, POS
- Interface to modem, mouse, plotter, printer, BBS
- RS-232 terminal interfaces
- Multi-drop communication networks
- Long-distance serial links
- Multi-user operating systems
- Laboratory data collection and process control

Specifications

Board

- **Number of ports:** 4
- **Protocol selection:** RS-232, RS-422 or RS-485 (jumper selectable)
- **UART:** PCL-746+ : 4 x 16C550 (16 byte FIFO)
- **Base I/O address selection:** From 100H to 3C0H
- **IRQ selection:** 3, 4, 5, 7, 9, 10, 11, 12 or 15
- **Interrupt status register:** From 000H to 3F0H
- **Data bits:** 5, 6, 7, 8
- **Parity:** Even, odd or none
- **Stop bits:** 1, 1.5, 2
- **Power consumption:** +5 V, 800 mA typical, 1.5 A max.
±12 V, 60 mA typical, 120 mA max.
- **Operating temperature:** 32 to 122° F (0 to 50° C)
- **Dimensions:** 185 mm x 98 mm
- **Weight:** 150 g

RS-232 Interface

- **Signals:** TxD, RxD, RTS, CTS, DTR, DSR, DCD, RI, GND
- **Mode:** Asynchronous full duplex, point-to-point
- **Max data rate:** 115 Kbps
- **Max data distances:** 50 feet (15.2 meters)

RS-422 Interface

- **Signals:**
TxD+, TxD-, RxD+, RxD-, RTS+, RTS-, CTS+, CTS-, GND
- **Mode:** Asynchronous full duplex, point-to-point
- **Max data rate:** 115 Kbps
- **Max data distances:** 4000 feet (1220 meters)

RS-485 Interface

- **Signals:** DATA+, DATA-, GND
- **Mode:** Half duplex, multi-drop
- **Max data rate:** 115 Kbps
- **Max data distances:** 4000 feet (1220 meters)

Connectors

- 30-cm male DB-37 to four male DB-25 cable
- **Weight:** 250 g

Programming Library (PC-ComLIB)

- Optimized, small-size resident (TSR) interrupt DOS driver
- Supports C, BASIC, Pascal, Clipper and assembly
- Includes DataScope data viewer, terminal emulator and self-diagnostic utilities for easy troubleshooting and debugging

CHAPTER
2

**Hardware
Configuration**

Initial Inspection

Depending on the option you ordered, you should find (in addition to this manual) the following items inside the shipping container:

PCL-746 +

- One PCL-746+ 4-port serial card (with 16C550 or compatible UART)
- One 30-cm male DB-37 to four male DB-25 cable
- One diskette with PCLS-802 PC-ComLIB software
- One PC-ComLIB user's manual

We carefully inspected the PCL-746+ mechanically and electrically before we shipped it. It should be free of marks and scratches and in perfect working order on receipt.

As you unpack the PCL-746+, check it for signs of shipping damage (damaged box, scratches, dents, etc.). If it is damaged or it fails to meet specifications, notify our service department or your local sales representative immediately. Also notify the carrier. Retain the shipping carton and packing material for inspection by the carrier. After inspection we will make arrangements to repair or replace the unit.

When you handle the PCL-746+, remove it from its protective packaging by grasping the rear metal panel. Keep the anti-vibration packing. Whenever you remove the card from the PC, store it in this package for protection.

Warning! *Discharge your body's static electric charge by touching the back of the grounded chassis of the system unit (metal) before handling the board. You should avoid contact with materials that hold a static charge such as plastic, vinyl and styrofoam. Handle the board only by its edges to avoid static damage to its integrated circuits. Avoid touching the exposed circuit connectors.*



PCL-746 + Switch and Jumper Layout

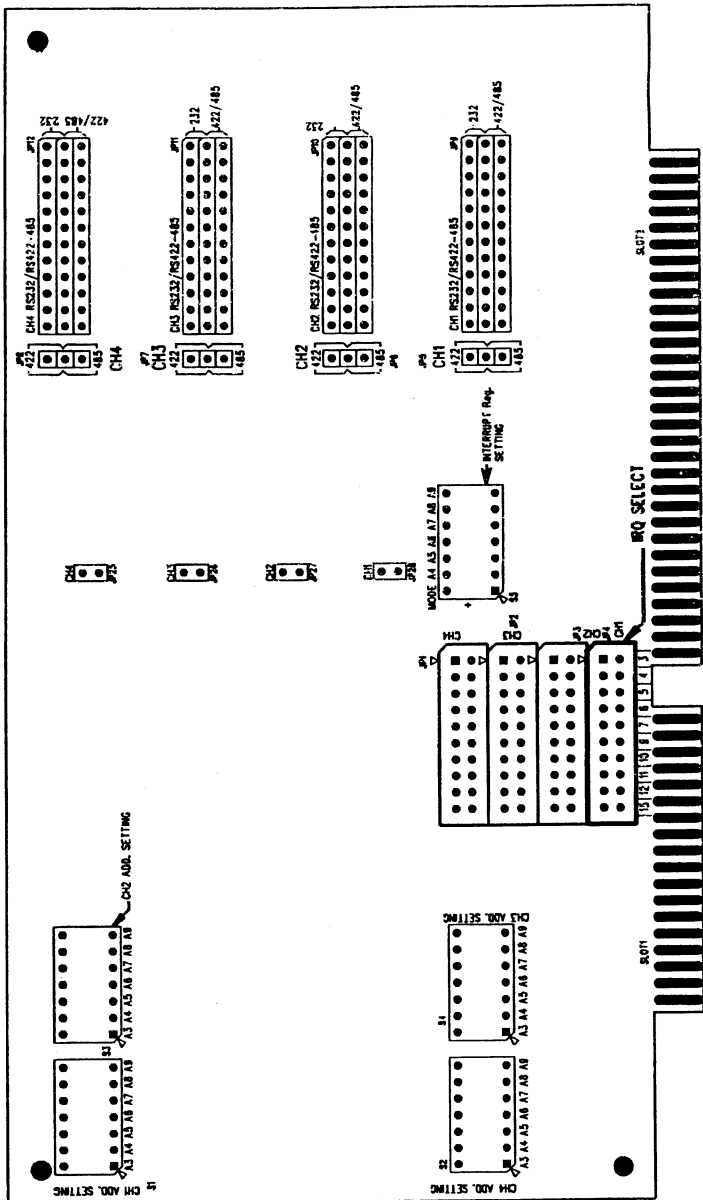

Jumper settings

This section tells how to set the jumpers to configure your card. It gives the card default configuration and your options for each jumper.

How to set jumpers

You configure your card to match the needs of your application by setting jumpers. A jumper is the simplest kind of electric switch. It consists of two metal pins and a small metal clip (often protected by a plastic cover) that slides over the pins to connect them. To “close” a jumper you connect the pins with the clip. To “open” a jumper you remove the clip. Sometimes a jumper will have three pins, labeled 1, 2 and 3. In this case you would connect either pins 1 and 2 or 2 and 3.

You may find pair of needle-nose pliers useful for setting the jumpers.

If you have any doubts about the best hardware configuration for your application, contact your local distributor or sales representative before you make any changes.

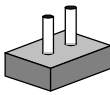

Open

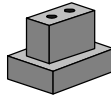

Closed

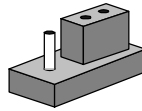

Closed 2-3

Card Configuration

Each port of the PCL-746+ card has two associated status jumper groups which require configuring prior to use. One group is to select either RS-232 or RS-422/RS-485 communication protocols. The other group selects RS-422 or RS-485. You will then need to select the cards appropriate I/O address and IRQ.

Default Settings

The board will be shipped in the RS-232 mode (Enhanced), all the jumpers on the 12*3 pin jumper will be set to the upper position, this is the cards default setting. The PCL-746+ DIP switch and jumper default settings are as shown below:

PCL-746+ Default Configuration	
Jumper	Default Function
Port1	RS-232
Port2	RS-232
Port3	RS-232
Port4	RS-232
JP4	IRQ12
S1	Address 300H
S5	Interrupt register 280H

Protocol Selection

Firstly you have to decide which mode each port will be operating in, RS-232, RS-422 or RS-485. You can configure each port to operate in a different mode if required. Each port has to be individually setup by selecting the correct jumper configurations on two jumper groups, one pair for each port. These consist of a 12*3 pin jumper (RS-232) and a 1*3 pin jumper (RS-422/RS-485).

Note: The second (RS-422/RS-485) jumper group is ineffective when the main jumper group is configured to operate in the RS-232 mode.

RS-232 or RS-422/RS-485 Mode Selection

Should you wish to configure the PCL-746+ to operate in the RS-232 mode, then the upper two pins of the 12*3 pin jumper should be connected. For RS-422/ RS-485 mode selection, the bottom two pins of the 12*3 pin jumper should be connected as shown below.

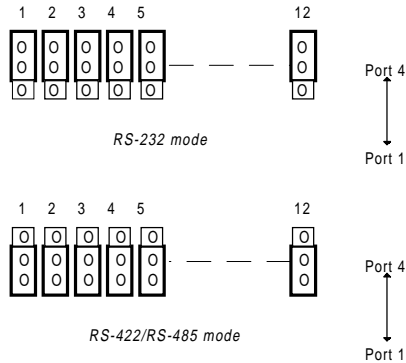

RS-422/RS-485 Mode Selection

For either RS-422 or RS-485 mode selection the 1*3 pin jumpers for each port have to be configured. For RS-422 configuration the upper two pins of the 3-pin jumper should be connected. A 2-pin jumper is used for Tx control. Closing the jumper initiates Tx automatic flow control. An open jumper means that Tx is always on. For RS-485 configuration the bottom two pins of the 3-pin jumper should be connected. The 2-pin jumper is always closed as shown below.

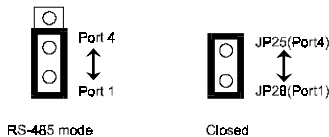
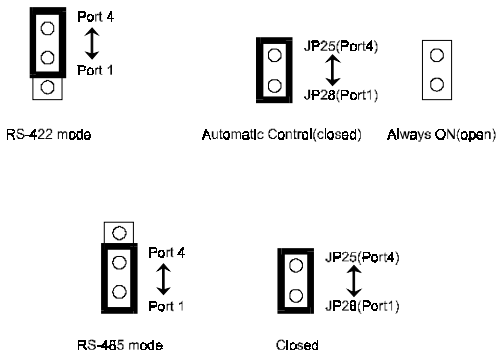

I/O Address and Interrupt Setup

Next you will need to select an IRQ (interrupt request) number and an I/O base address for the PCL-746+.

Mode Setup (S5)

The cards base address can be setup using S5. Please note that the first DIP switch is for mode setting as shown below.

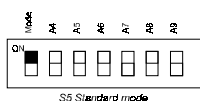

Standard Mode

In this mode each of the four ports can be setup as the address or the IRQ channel individually.

- Port1 CH1 Base Address AAA, CH1 IRQ M
- Port2 CH2 Base Address BBB, CH2 IRQ N
- Port3 CH3 Base Address CCC, CH3 IRQ O
- Port4 CH4 Base Address DDD, CH4 IRQ P

Enhanced Mode

In this mode all four ports share the same IRQ and continue to use the cards designated IRQ address. This mode also utilizes an interrupt status register designed to indicate which serial port has generated an interrupt. This speeds up interrupt processing resulting in a greater throughput for each multi-port card.

- Port1 CH1 Base Address AAA, CH1 IRQ M
- Port2 CH2 Base Address BBB, CH1 IRQ M
- Port3 CH3 Base Address CCC, CH1 IRQ M
- Port4 CH4 Base Address DDD, CH1 IRQ M

In the above table the base address is set by S1~S4 and the IRQ channel number set by the IRQ select jumper JP4 (see page 15).

I/O Base Address (S1 ~ S4)

Select an address which is not already in use by another card in the system. **If you are installing more than one PCL-746+ card in your system, set the cards to different base addresses.** DIP switches S1~S4 control the card(s) base address, as shown:

S1~S4 (DIP Switch Figure)



Card base address (S1 ~ S4)

Base address	A3	A4	A5	A6	A7	A8	A9
100H	●	●	●	●	●	○	●
108H	○	●	●	●	●	○	●
110H	●	○	●	●	●	○	●
•							
•							
•							
* 300H (CH1)	●	●	●	●	●	○	○
* 308H (CH2)	○	●	●	●	●	○	○
* 310H (CH3)	●	○	●	●	●	○	○
* 318H (CH4)	○	○	●	●	●	○	○
•							
•							
•							
3F8H	○	○	○	○	○	○	○

○ = Off ● = On * = default

Standard Mode IRQ Selection (JP1 ~ JP4)

In this mode each of the four ports can have the IRQ channel set individually. For each port, select an IRQ which is not already in use by another card in the system. The map of jumpers and ports is shown below:

Port 1	★	JP4
Port 2	★	JP3
Port 3	★	JP2
Port 4	★	JP1

Enhanced Mode IRQ Selection (JP4)

Select an IRQ which is not already in use by another card in the system. **If you are installing more than one PCL-746+, set them to a different IRQ number.** Jumper bank JP4 controls the card IRQ. Simply place the jumper on the required interrupt level as shown in the following figure.

JP4 IRQ12 (default)

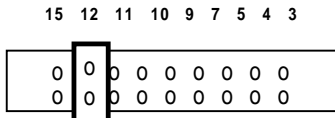

Interrupt Status Register Setup (S5)

This feature on the PCL-746+ is utilized in the enhanced mode only. When data arrives at one of the four ports, it will generate an interrupt in the interrupt register. The PC software can read this and identify immediately which port generated the interrupt. This saves time and makes programming easier. When a data bit of the interrupt status register is set to 0, the corresponding channel is selected to generate an interrupt. If the bit is 1, then no interrupt is generated. DIP switch S5 controls the cards interrupt status register, as shown in the following figure and table:

S5 280H (default)



Interrupt status register S5

Bit	Function
0	Port 1
1	Port 2
2	Port 3
3	Port 4
4	Not Used
5	Not Used
6	Not Used
7	Not Used

The user may change the interrupt status address via S5. Please note that the address decoder will occupy a continuous 16 bytes of area related to the switch setting. For example, if you set the switch to 010H, then the address 010H to 01FH will all be decoded. The various DIP Switch settings (S5) for the Interrupt status register are as follows:



000H



010H

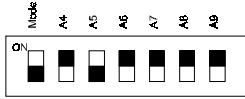

020H



030H



040H

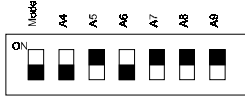

050H



060H



070H

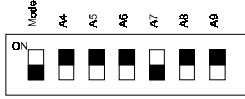

080H



090H



0A0H



0B0H



0C0H



0D0H

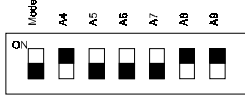

0E0H



0F0H



100H



110H

S5 DIP switch settings 000H to 110H

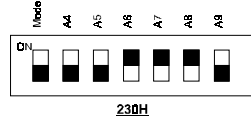
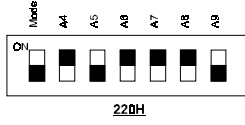
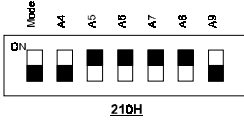
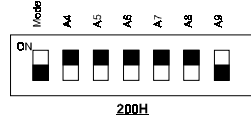
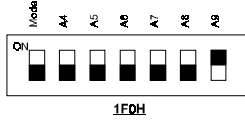
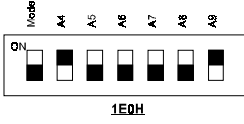
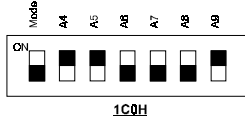
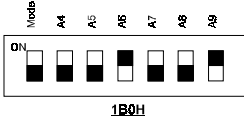
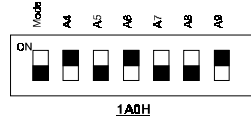
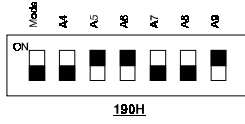
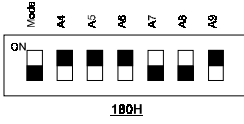
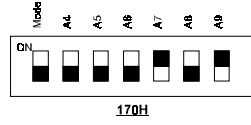
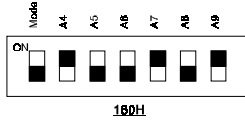
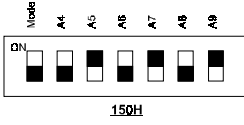
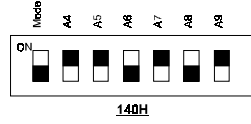
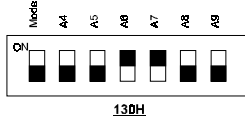
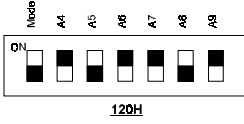

S5 DIP switch settings 120H to 230H

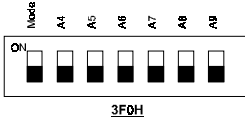
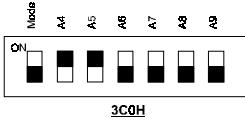
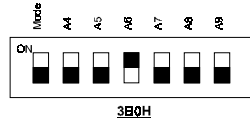
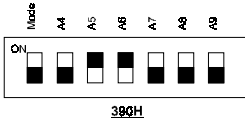
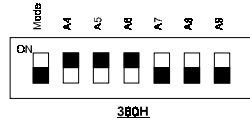
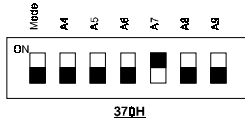
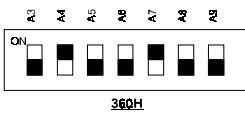

S5 DIP switch settings 360H to 3F0H

CHAPTER

3

Installation

Card installation



Warning! Turn off your PC's power supply whenever you install or remove the PCL-746+ or its cables. Static electricity can easily damage computer equipment. Ground yourself by touching the chassis of the computer (metal) before you touch any boards. See the static warning on page 8

1. Turn off the computer. Turn the power off to any peripheral devices (such as printers and monitors).
2. Disconnect the power cord and any other cables from the back of the computer. Turn the PC if necessary to gain access to the cables.
3. Remove the PC's cover (refer to your user's guide if necessary).
4. Locate the expansion slots or passive backplane (at the rear of the PC) and choose any unused slot.
5. Remove the screw that secures the expansion slot cover to the PC (save the screw to secure the interface card retaining bracket). Remove the anti-vibration card clamp if supplied.
6. Carefully grasp the upper edge of the PCL-746+ card. Align the hole in the retaining bracket with the hole on top of the expansion slot. Align the gold striped edge connector with the expansion slot socket. Press the board firmly into the socket.
7. Replace the screw in the expansion slot retaining bracket. Replace anti-vibration card holder.
8. Replace the PC's cover. Connect the cables you removed in step 2. Turn the computer power on.
9. Attach the DB-37 cable to the connector on the bracket.

The board is now installed in the computer. See Chapter 6 for information on cabling.

CHAPTER

4

**Software
Installation:**

Driver Installation for DOS Users

The PCL-746+ comes with the PC-ComLIB software package. PC-ComLIB provides a software driver for DOS which supports most common languages, including C, PASCAL, Visual Basic, Quick Basic, assembly and Clipper. PC-ComLIB also includes DataScope data viewer, terminal emulator and self-diagnostic utilities for easy troubleshooting and debugging. Please see the PC-ComLIB manual for more detailed information.

Card setup

The PCL-746+ driver determines the configuration of the installed cards by reading a data file, `GEN-DRV.CNF`. When you first install the PCL-746+, and each time you change the jumper or DIP switch settings, you will need to run the card setup program to save the settings to the configuration file.

Program files should be installed to the hard disk. Insert the driver disk in your computer, type `DOSINST` from the A: (or B:) prompt and press Enter. Once the files have been installed, type `SETUP` from the `\COMLIB\BIN` prompt and press `ENTER`. The screen shown at right will be displayed.



Driver selection screen

After the screen shows up, move the cursor bar (using the arrow keys or the mouse) to the General Serial I/O Card field and press ENTER.

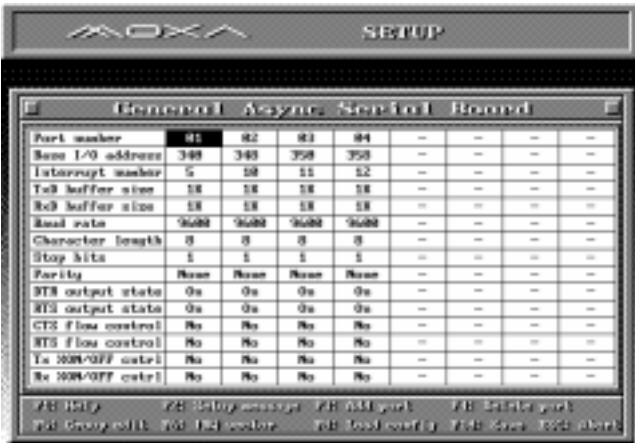

PCL-746+ Setup screen

Here you can set the configuration for each of the PCL-746+ cards installed in the system. Set the IRQ, base address, baudrate, buffer size and port number to match the card's configuration. Do this by moving the highlight to the field you want to set up. Press ENTER and a menu will appear, allowing you to select the correct setting.

The setup program also controls the port number assignments for each card. When you use a driver function in your program, you will identify the ports by these assignments. After you have set the IRQ, base address, baudrate, buffer size and port assignments, press F10 to save the settings or ESC to return to the previous page.

Note: *Make sure that the base address and IRQ selected do not conflict with any other cards you may have installed in your system.*

If any of your ports have the same setup, you can define them all at one time by pressing F5 to bring up the Group Setup screen shown below.

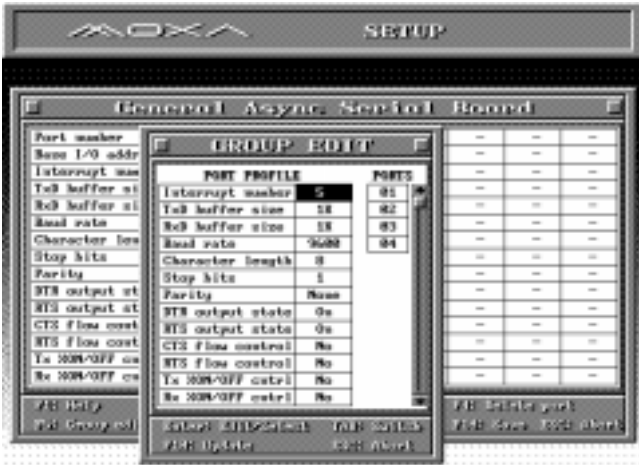

Group Edit menu

When you are finished setting up the ports, press the ESC key to return to the previous windows. Press F10 to save the new configuration or ESC to quit without saving. The setup program will then create a new configuration data file GEN-DRV . CNF .

DOS Driver Installation

You must install the PCL-746+ card driver (GEN-DRV . EXE) before you run any application programs, including the DataScope utilities. If you are installing the driver for the first time, you will need to run the setup program (described in the previous section) to save the initial status of the PCL-746+.

Because the driver is a TSR (terminate and stay resident) program, you can execute it at any time. You do not have to install it in the CONFIG.SYS file.

To install the PCL-746+ card driver, change to the directory or floppy disk containing the driver files and type GEN-DRV. You should soon see the following message:

```
PC-ComLIB Serial Communication Driver (Ver x.xx)
```

```
Setup driver...
```

```
Device driver setup O.K.
```

If the driver cannot detect any card or the GEN-DRV . CNF configuration file is not in the same directory as the driver, the following message will be displayed:

```
PC-ComLIB Serial Communication Driver (Ver x.xx)
```

```
Setup driver...
```

```
No serial port found!!
```

Driver Removal

To remove the driver TSR program, just type GEN-DRV/q from the DOS prompt. The following message will appear:

```
PCL-746 Device Driver Release O.K.
```

Programming

The following code extract illustrates how the library functions can simplify card programming, reduce setup time and avoid any bugs. The following C program shows a simple data transfer test. It uses a PC-ComLIB function call to send data between Port 1 and Port 2 at a rate of 57.6 Kbps

```
/* Execute the PC-ComLIB TSR driver first*/
#include<head-c.h>
main()
{
    /* Setup PORT1 & PORT2 : baud = 57600 data = 8 stop = 1 no
    parity */
    sio_ioctl(1,B57600,BIT_8|P_NONE|STOP_1);
    sio_ioctl(2,B57600,BIT_8|P_NONE|STOP_1);

    /* Enable communication ports */
    sio_open(1);
    sio_open(2);

    /* Transmit data on Port 1 */
    sio_write(1," Hello ",7);
    delay(200);

    /* Receive data on Port 2,store in buf1*/
    sio_linput(2,buf1,7,13);

    /* Print received data */
    printf("%s\n",buf1);

    /* Disable communication ports */
    sio_close(1);
    sio_close(2);
}
```

See the PC-ComLIB user's manual for information on programming and linking your application programs with the driver libraries.

Driver Installation for Windows Users

Windows 3.1 provides a versatile and easily configurable interface that supports up to four COM ports with a standard driver. The PC-ComLIB Standard Windows COMM Driver, along with PCL-746+, allow users to install up to six serial ports under Windows 3.1.

The Standard Windows COMM Driver supports Microsoft Windows COMM API (Application Programming Interface) such as OpenComm(), ReadComm(), and WriteComm(). Application software like Windows Terminal program, pcANYWHERE for Windows, or other programs that support Windows COMM API calls can communicate to outside world via PCL-746+ multiport boards.

Installing the Standard Windows COMM Driver

1. Insert the PC-ComLIB diskette into the floppy drive A: (or B:).
2. In Windows File Manager, execute A:\WININST (or B:\WININST).
A **Driver Installation** sub-window will appear.

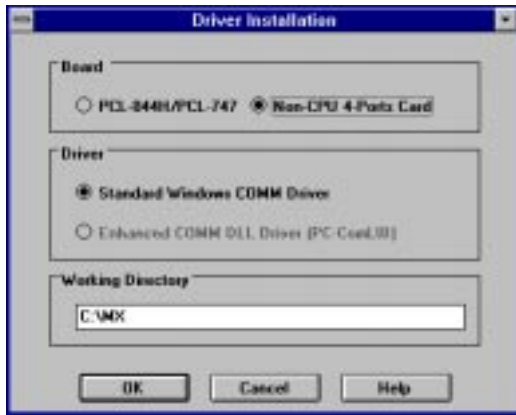

Driver Installation

3. Choose the board type, driver type, and the working directory to which the software will be copied when using PCL-746+.

A maximum of 6 ports is supported if the existing standard COM ports (COM1 and COM2) are included. For example, you can set one serial port on the motherboard for COM1 (0x3F8, IRQ4), while designating COM2-5 on IRQ3 for the four ports on a PCL-749 card.

Note: If using a serial mouse, it must be installed on either COM1 (0x3F8, IRQ4) or COM2 (0x2F8, IRQ3), and must have its own dedicated IRQ.

The utility TTY, which can manipulate ports from COM1 to COM9, is included to help users monitor and debug RS-232 communications under Windows 3.x. It is a simple example program capable of sending and receiving data after each port is opened with selected communication parameters. As Windows 3.x features multitasking, multiple windows for the ports can appear simultaneously under TTY. However, Terminal, the application provided by Windows is limited for the use of COM1 to COM4.

After completing the installation, restart Windows. An additional line, "comm.driv=sercomm.driv", will appear for the PCL-746+ in the [boot] section of the Windows SYSTEM.INI file. In addition, a Windows group "PC-ComLIB Standard COMM Driver" will be generated for reconfiguration, driver removal, etc. At this point, you are ready to execute applications that support Windows COMM API calls.

CHAPTER
5

**Software
Installation**

For UNIX Users

SCO UNIX/XENIX

The PCL-746+ is compatible with Arnet 4-port cards. Under SCO UNIX/XENIX you can install up to two cards in one system . The two four port cards should be set to **Enhanced** mode and the switch settings are as follows:

Primary: Interrupt 4

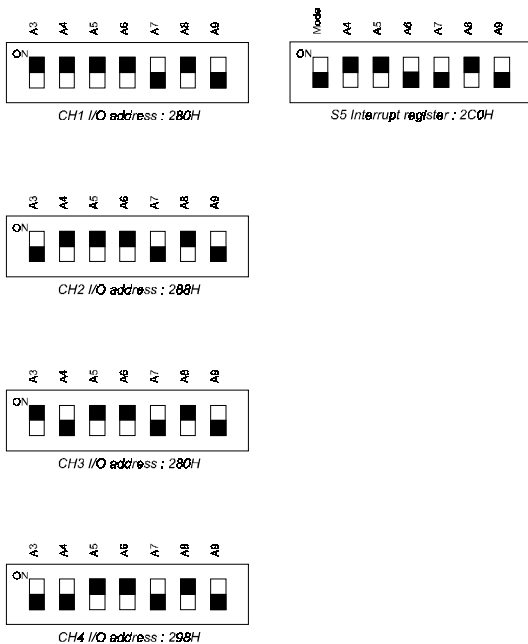

Secondary: Interrupt 3



CH1 I/O address : 300H

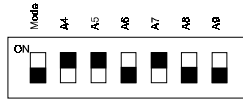

S5 Interrupt register : 340H



CH2 I/O address : 308H



CH3 I/O address : 310H



CH4 I/O address : 318H

After you have set the above switches to the appropriate settings please enter the system maintenance mode and type:

```
# mkdev serial
```

The screen will display;

You would like to install a :

1. 1 port card
2. 2 port card
3. 4 port card
4. 5 port card
5. 8 port card

Enter number 3 and then press return. The screen will show:

The card is configured as:

1. COM1
2. COM2
3. COM3
4. COM4

Enter number 1 and press enter. The system will configure the 4 port card as tty1a, tty1b, tty1c, and tty1d. Repeat the above procedure to configure a secondary 4 port card if required, the system will configure the secondary 4 port card as tty2a, tty2b, tty2c, and tty2d. You may then enable the tty by entering:

```
# enable tty1a  
  
# enable tty1b  
  
....  
  
....  
  
# enable tty2c  
  
# enable tty2d
```

At this point you may connect the system up as necessary.

CHAPTER

6

Wiring

Wiring

RS-232 signal wiring

Since the RS-232 interface is not strictly defined, many devices have their own connection methods which may ignore some signal lines or define reserved lines for other functions. It is best to refer to the user's manual for your device for installation instructions. You may find the following helpful.

In general, DTE (Data Terminal Equipment) refers to the device that is leading the communication. Examples include PC's, terminals and some printers. DCE refers to the device being communicated with or controlled. Examples include modems, DSU's (digital service units), printers and lab/factory equipment.

In some situations you may be able to get by with just three lines: data on TXD, a signal ground and a handshaking line. Examples are printer or plotter connections, troubleshooting and situations where you require only one-wire communication.

Terminal or PC (DTE) connections

DB-25 Male: PCL-746 +		DB-25 Male or Female: Terminal	
Pin	Signal	Pin	Signal
2	TxD	3	RxD
3	RxD	2	TxD
4	RTS	5	CTS
5	CTS	4	RTS
6	DSR	20	DTR
7	GND	7	GND
20	DTR	6	DSR
8	DCD	8	DCD

Modem connections

DB-25 Male: PCL-746+		Modem (DCE)	
Pin	Signal	Pin	Signal
2	TxD	2	RxD
3	RxD	3	TxD
4	RTS	4	CTS
5	CTS	5	RTS
6	DSR	6	DTR
7	GND	7	GND
20	DTR	20	DSR
8	DCD	8	DCD

For DTE to DCE connection, use straight through cable, i.e. you don't have to reverse lines 2 and 3, lines 4 and 5, and lines 6 and 20.

Because in general the DCE RS-232 interfaces are reversed themselves.

Terminal without handshake

DB-25 Male: PCL-746+		Terminal, PC (DTE)	
Pin	Signal	Pin	Signal
2	TxD	3	RxD
3	RxD	2	TxD
4	RTS		
5	CTS		
7	GND	7	GND
6	DSR		
20	DTR		
8	DCD		

The maximum length of a RS-232 cable is 100 ft. If you need to connect over longer distances, (longer than 100 ft), please use RS-422 or RS-485 modes to match this requirement.

If not using CTS, RTS, DSR ,DTR signals, please loop back for the PC-ComLIB software to function correctly, because PC-ComLIB will always check for handshake signals.

RS-422 signal wiring

For RS-422 interface, the wiring is based on one-to-one principle and the connections are as follows:

DB-25 Male: PCL-746+		DB-25 Male or Female: Terminal	
Pin	Signal	Pin	Signal
2	RxD+	3	TxD+
3	TxD+	2	RxD+
4	RTS+	5	CTS+
5	CTS+	4	RTS+
6	RTS-	22	CTS-
7	GND	7	GND
20	RxD-	8	TxD-
8	TxD-	20	RxD-
22	CTS-	6	RTS-

Terminator Resistors setup

The signals DSR, DTR, DCD are shorted internally on PCL-746+ card whist operating in the RS-422 mode.

The terminal resistors for impedance matching on the PCL-746+ are not installed at the factory. The user can install the resistors with the appropriate resistances according to the cards application. Each terminal resistor corresponds to a different channel for TxD+/- or RxD+/- lines. Usually, these resistors are needed for both ends of the communication wires and the value of the resistors should match the characteristic impedances of the wires used (approx 120 ohm).

An example of the installation for port 4 is as follows:

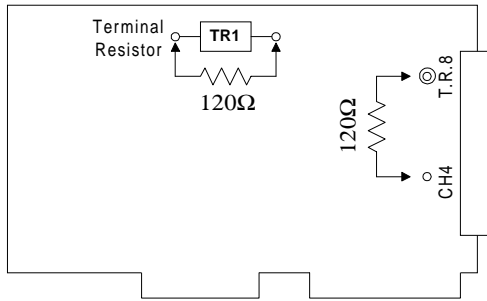

RS-422 Termination resistor installation

RS-485 Signal wiring

The RS-485 standard supports half-duplex communication. This means that just two wires are needed to both transmit and receive data. Handshaking signals (such as RTS, Request To Send) are normally used to control the direction of the data flow and to switch the transmission accordingly. In RS-485 mode, the PCL-746+ automatically senses the direction of the data flow and switches the transmission direction hence no handshaking is necessary. This means a user can build an RS-485 network with just two wires. This RS-485 control is completely transparent to the user. The Software written for half duplex RS-232 works without the need for any modification. The connections are as follows:

DB-25 Male: PCL-746+		DB-25 Male or Female: Terminal	
Pin	Signal	Pin	Signal
3	DATA+	3	DATA +
7	GND	7	GND
8	DATA-	8	DATA -

Terminator Resistors setup

The terminal resistors for impedance matching on the PCL-746+ are not installed at the factory.

The user can install the resistors with the appropriate resistances according to the cards application. Each terminal resistor corresponds to a different channel for DATA+, DATA- lines. Usually, these resistors are needed for both ends of the communication wires and the value of the resistors should match the characteristic impedances of the wires used (approx 120 ohm).

An example of the installation for port 4 is as follows:

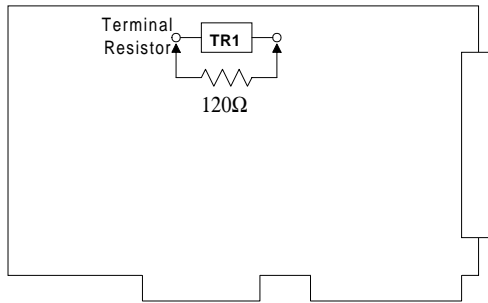

RS-485 Termination resistor installation

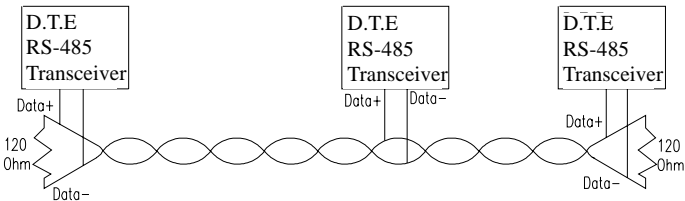

RS-485 Wiring topology

APPENDIX
A

**Connector Pin
Assignments**

The following diagrams show the pin assignments for DB-37 and DB-25 connectors for RS-232, RS-422 and RS-485 Modes.

Four Port Connectors:DB-25

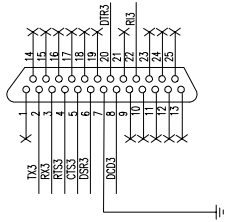

COM3

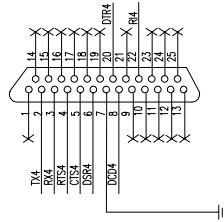

COM4

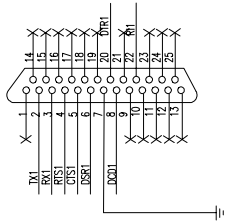

COM1

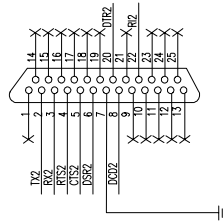

COM2

PCL-746+: DB-37

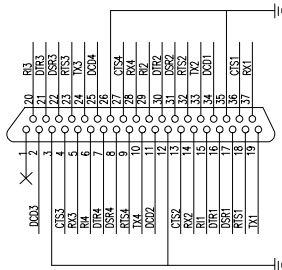

PCL-746+ Pin assignment for RS-232

PCL-746+: DB-37

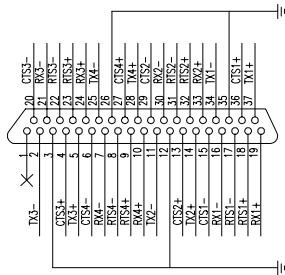

Four Port Connectors: DB-25

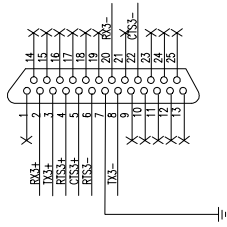

COM3

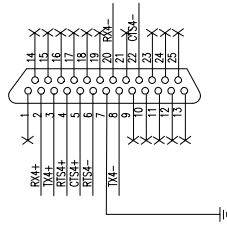

COM4

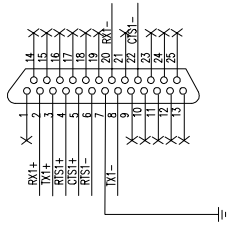

COM1

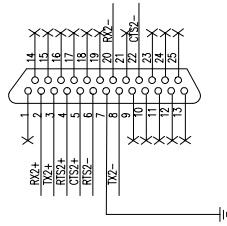

COM2

PCL-746+ Pin assignment for RS-422

PCL-746+ Pin assignment for RS-485

PCL-746+: DB-37

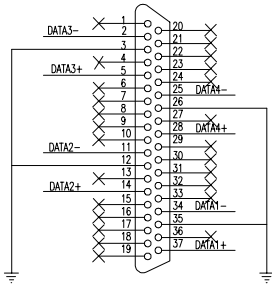

Four Port Connectors:DB-25

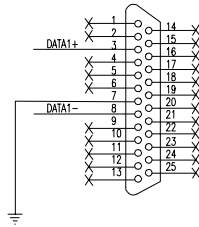

COM1

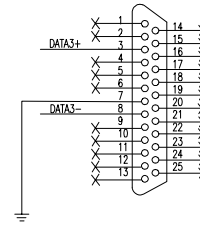

COM3

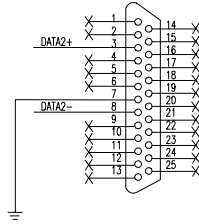

COM2

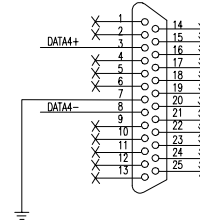

COM4

APPENDIX **B**

**PC I/O Address
Reference**

APPENDIX B PC I/O Address Usage

The following table indicates the PC I/O address usage assignment. To prevent conflicting settings of the PCL-746+ with other devices or I/O cards, you are recommended to refer this table.

I/O Address	Device
000 - 00F	DMA (8237A)
020 - 021	8259A IRQ Controller
040 - 043	8253/8254 Timer/Counter
060 - 063	PPI 8255A
070 - 071	Real-Time Clock
080 - 08F	DMA Page Register
0A0 - 0BF	8259A Interrupt Chip
0C0 - 0DF	Second DMA Controller 8237A
0F0 - 0FF	Math Coprocessor
1F0 - 1F8	AT Fixed Disk
200 - 20F	Game I/O
278 - 27F	Serial I/O Port #2
2F8 - 2FF	Serial Adaptor (COM 2)
320 - 32F	XT Fixed Disk
378 - 37F	Parallel Printer Adaptor
380 - 38F	SDLC Binary Communication Adaptor
3A0 - 3AF	Master Binary Communication Adaptor
3B0 - 3BF	Monochrome/Parallel Adaptor
3D0 - 3DF	Color Graphics Adaptor
3F0 - 3F7	Diskette Controller
3F8 - 3FF	Serial Adaptor (COM 1)